

# Sliding rail door and window dedicated electric hook lock

## Model: HL-210

### Parameters

Lock Body	79Lx45.5Wx34.3H(mm)
Door Catch	91Lx30Wx25.85H(mm)
Voltage	12VDC
Current	100mA
Holding Force	300kg
Operating Temp	-40℃~+50℃
Operating Humidity	> 95%
Weight	0.35kg

### Features

- Installed on hollow metal doors, plastic-steel doors and other sliding rail type doors and windows.
- The standard appearance of the structure apply to various brand hollow metal and plastic-steel doors and windows.
- The fixed installation parts can be installed on the frame, cylindrical assemblies embeds in the frame, easy to install.
- There are anticorrosion coating protection for Latch bolt components and Lock bolt
- The Fail safe feature design, meet with the demand of emergency exit
- The special usage design, during the product life cycle, it don't need to do preventive maintenance and lubricant, etc

### Dimensions

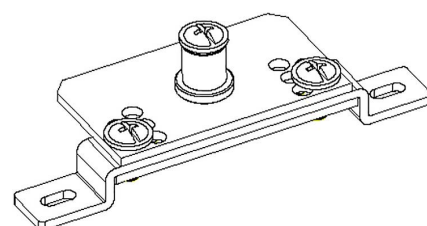
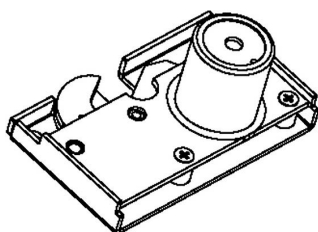
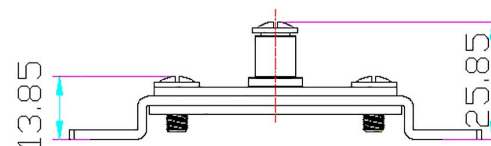
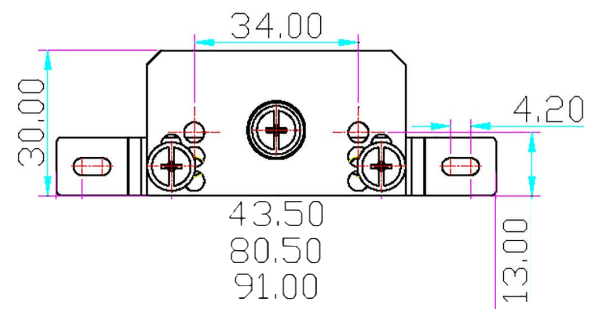
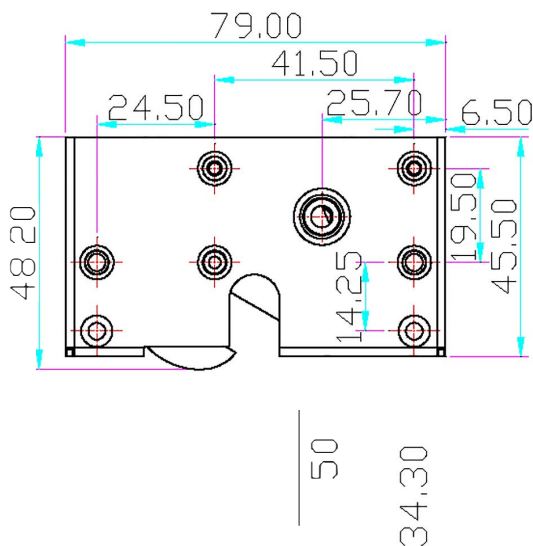

# Installation

## Mounting and operating principle:

Normal lock operating is optimized for a backlash between a door case and a door within a range 10-15mm.

External lock base and mounting plate are made in special standard shape and suit for the majority of plastic moldings, which are made in Russia. The lock can be installed on the outside doors if the lock will be closed (a voltage will be supplied) most of the time in winter.

Mountable lock's part, which is installed inside the molding, is cylindrical which makes in stalling easier it is enough to perforate a hole and put the lock there. It permits to minimize joiner work.

Engineering design anticipates locking point position adjustment in horizontal and vertical planes. To adjust locking point position, depending on lash between the door case and the door, adjusting shims are used. Latch gear has to devices; locking point bowl blocker and blocker disable. Blocker is used to hold locking point, disable locking point shutting in the lock.

After voltage removal disable makes blocker free and it is necessary for door opening to overcome disable force.



Sliding rail door



Door frame



Door leaf

# Wiring Diagram

